

Low Profile Hexagon Hydraulic Torque Wrench

- Repeatability $\pm 3\%$
- Working pressure 10000 psi max
- 5 different models from 170 ft.lbs to 32,819 ft.lbs
- Designed to tighten and loosen nuts requiring high torque
- 360°x185° uni.swivel quick release couplings
- Maximum torque power with minimum wall thickness
- Various cassettes, adaptors and reducers are available
- Durable structure, aluminium-titanium alloy drive cylinder
- Suitable for continuous operation at maximum pressure
- Pressure relief valve prevents over pressure

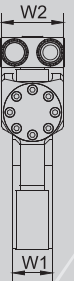
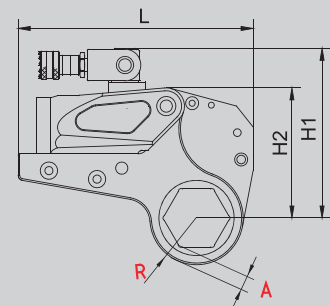
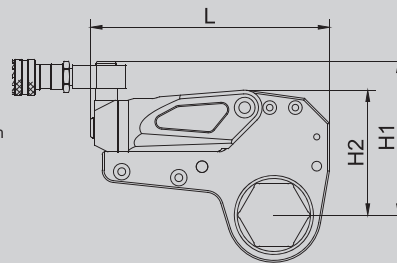
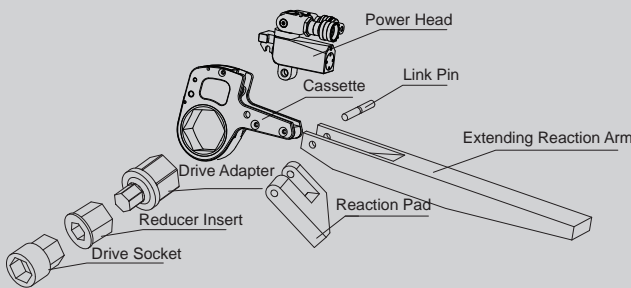

Type	A/F (inch)	Torque (ft.lbs)		Drive Cylinder (lbs)	Cassettes (lbs)	Dimension (inch)						
		Min	Max			L	H1	H2	W1	W2	A	R
LFT-2	7/8" ~ 2-3/16"	169	~ 1,691	2.20	3.52	7.69	4.96	4.03	1.26	2.01	0.39~0.63	1.06~1.69
	2-3/8"	177	~ 1,770	2.20	3.74	7.69	5.06	4.14	1.26	2.01	0.43	1.81
LFT-3	1-3/8" ~ 2-3/8"	250	~ 2,503	3.20	3.75	8.69	6.06	4.64	1.36	2.30	0.48	1.85
LFT-4	1-1/4" ~ 2-9/16"	470	~ 4,703	4.40	9.68	10.15	6.97	5.35	1.65	2.60	0.55~0.63	1.42~2.09
	2-3/4" ~ 3-1/8"	476	~ 4,775	4.40	10.12	10.35	7.37	5.74	1.65	2.60	0.59	2.2~2.4
LFT-8	1-7/16" ~ 3-11/16"	795	~ 7,948	7.26	17.60	11.96	8.16	6.66	2.09	3.27	0.63~0.87	1.81~2.36
	3-7/8" ~ 4-1/4"	867	~ 8,864	7.26	18.48	11.96	8.51	7.01	2.09	3.27	0.67	2.95~3.07
LFT-14	2" ~ 4-5/8"	1,346	~ 13,456	12.10	25.52	14.25	9.42	8.04	2.52	3.90	0.75~1.22	2.36~3.43
LFT-18	3-1/2" ~ 4-3/4"	1,804	~ 18,031	17.86	42.55	15.90	9.52	10.04	2.68	4.13	0.85~1.26	2.66~3.93
LFT-20	3-1/2" ~ 5"	2,139	~ 21,389	23.15	49.16	16.81	9.54	10.43	2.76	4.33	0.88~1.28	2.68~3.96
LFT-30	2-3/8" ~ 6-1/8"	3,043	~ 30,426	25.08	63.80	16.57	11.94	10.72	3.35	5.16	0.98~1.14	3.03~4.53
	6-1/2" ~ 6-7/8"	3,282	~ 32,819	25.08	66.00	17.05	12.41	11.23	3.35	5.16	1.06~1.42	4.8~5.04
LFT-45	5" ~ 6-1/8"	4,454	~ 44,534	35.94	129.41	19.13	12.24	13.86	4.13	6.30	1.16~1.52	4.9~5.14
LFT-60	5-3/8" ~ 6-7/8"	6,187	~ 61,875	50.71	165.35	20.24	13.23	14.76	4.60	6.98	1.26~1.62	5.1~5.24